



Smoking & Vaping Machine

Flexible & fully programmable

Highly configurable PDF reports & data logging

Compatible with combustibles, heat-not-burn, e-cigarettes and more

With over 15 years of continuous development, the Cambustion SCS has been adopted globally by the tobacco, e-cigarette and cannabis

industries.

The SCS's flexibility and repeatability make it ideally suited for both product development and

Applications:

- Quality control testing
- Product development
- Pressure drop & clogging
- Device repeatability & reproducibility
- User acceptance testing
- Supports chemical characterisation

Features and

- Widest range of compatible products for testing
- Reproduces ISO 3308, 20768, 22486, Health Canada Intense and custom regimes
- Reproduce real world smoking topographies
- Provides smoke for a range of analytical techniques
- Unlimited puff volume and duration
- Programmable actuator option for e-cigarettes

Introduction

Offering unrivalled flexibility and compatibility with a wide range of products and analytical techniques, Cambustion's SCS has been the tool of choice for both R&D and QC applications across a variety of industries since 2006.

Applications

Tobacco cigarettes / cigars

The SCS offers pre-programmed support for ISO3308, Health Canada Intense and the opportunity to create custom smoking regimes.

Water pipes

The SCS is available with an option to reproduce higher flows, allowing testing of water-pipes ("shisha" / "hookah") to the ISO22486 standard or user defined real-world profiles.

Heat-not-burn

The SCS supports heat-not-burn devices, with an additional option to monitor temperatures inside the device via an inserted thermocouple for development purposes.

e-cigarettes



e-cigarettes have a wide variety of form factors, including automatically triggered "cig-alike" types and larger tank systems which must be manually triggered by the user.

The SCS offers pre-programmed support for the ISO20768 e-cigarette regime, and users can easily create additional custom smoking regimes.

A distinct advantage of the SCS for e-cigarette applications is the absence of individual puff volume or puff repeat count limits - beneficial when performing durability or battery testing.

An optional button pusher accessory (shown below) offers automated and programmable "press & release" of the button on a manually activated e-cigarette - offering both repeatability and flexibility.

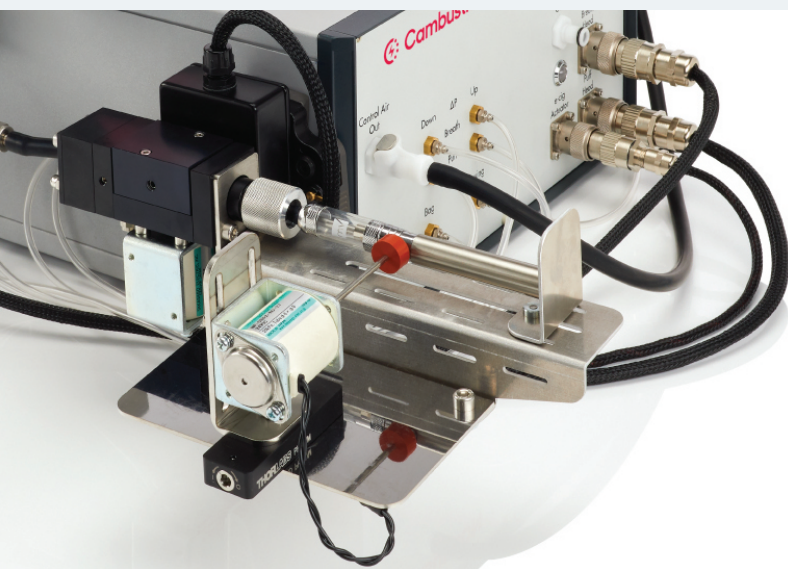

The SCS offers an option to insert a thermocouple into a device under test to record temperature data during vaping.

Cannabis



Pre-rolls



Pre-roll cannabis products offer some unique challenges in smoking.

Pre-rolls are commonly cone shaped, although cylindrical products are also available. The SCS's flexible labyrinth seals in a range of sizes ensure reliable and easy sealing on the joint to be tested.

Cannabis combustibles can suffer from high resin content, leading to clogging and an unacceptable resistance to draw. This clogging only becomes apparent as the pre-roll is partially smoked - measurements of the unlit product are insufficient. The SCS supports smoking regimes designed to specifically identify this issue, and guide production / QC teams in identifying solutions.

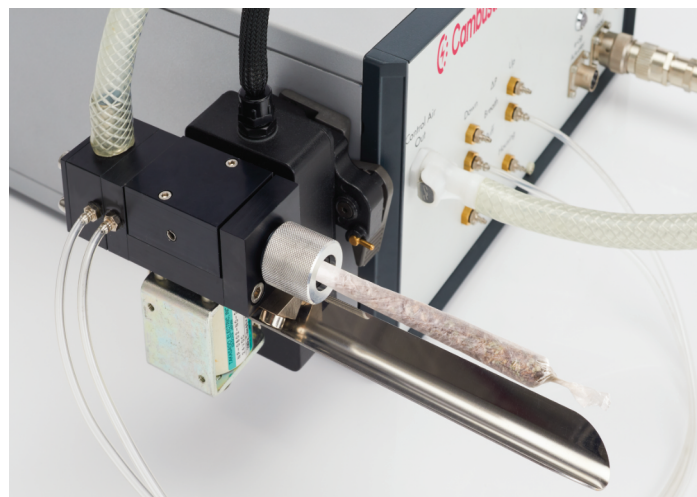

Cannabis chemistry is complex, and as a natural product can vary in composition. The SCS's sample collection flexibility is particularly advantageous. The use of gas-bag sampling to offer puff-by-puff collection for subsequent analysis offers critical insights into product chemistry.

Cannabis e-cigarettes & vaporisers

Although the principles of cannabis e-cigarettes and vaporisers are similar to others, the different composition of the oils and the effect of heat on the cannabis chemistry mean that particular attention is required both in product development and QC.



Flexible collection of aerosol and gases for analysis offers valuable insights into device performance as well as consumable properties.

(see also general e-cigarettes section above)

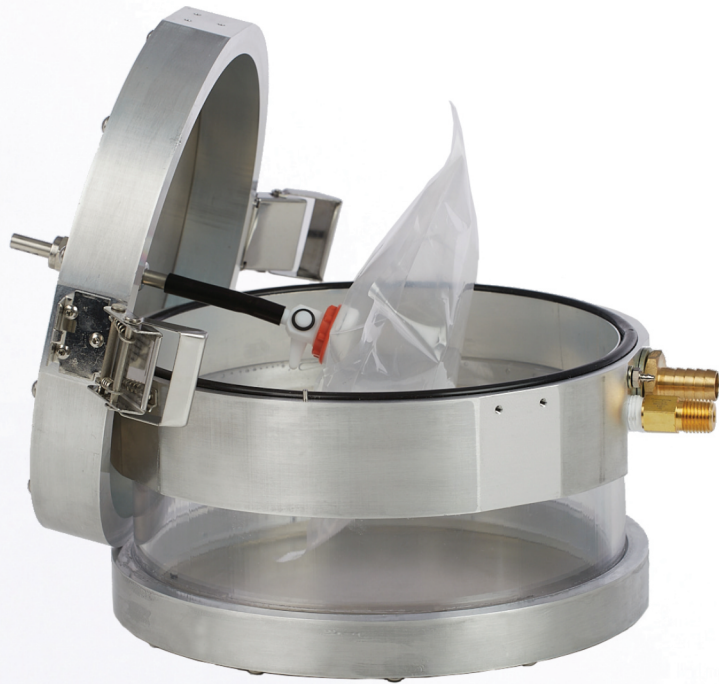

gas bag sampling accessory



Cambustion SCS Smoking and Vaping

Operating principles

The SCS controls flow through a product under test by balancing two flows; HEPA filtered compressed air (provided by a blower, and controlled by an electronic valve) and a fixed vacuum flow drawn into a pump.

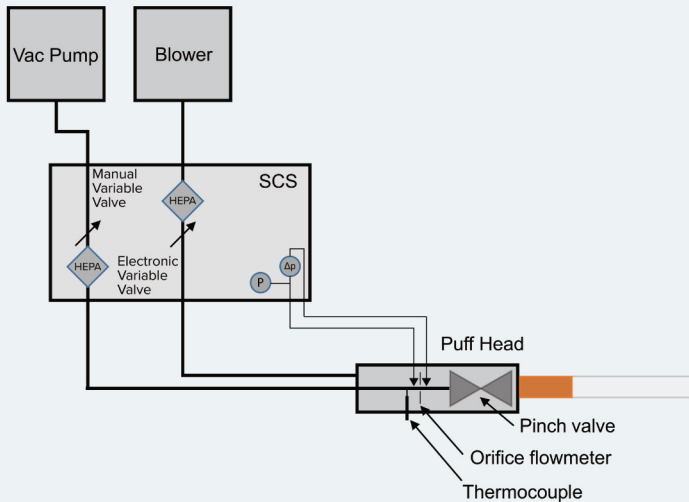

By varying the flow of compressed air, the pressure in the puff head (at the exit end of the product under test) may be varied. If the pressure in the head is atmospheric, then when the pinch valve opens, no flow is drawn through the product.

By reducing the flow of compressed air, the pressure in the puff head becomes below atmospheric, and atmospheric air will flow through the product under test when the pinch valve is opened.

An orifice flowmeter enables accurate control and data recording of the flow through the product, using input data of absolute pressure & orifice pressure drop, and direct measurement of the gas temperature.

The orifice flowmeter is calibrated against an internal reference mass flow meter.

Basic configuration

The basic SCS configuration shown above is suitable for many common applications for a variety of test products.

Collecting material on filter pads, sending live smoke to online analysis equipment or simply smoking / vaping for product development, quality control and excise determination purposes are all possible.

Switching between configurations

When ordered with additional capabilities beyond the basic SCS, the user can easily switch between the different configurations.

Puff inhalation exhalation configuration

A more sophisticated configuration adds a second head and a flexible lung bag.

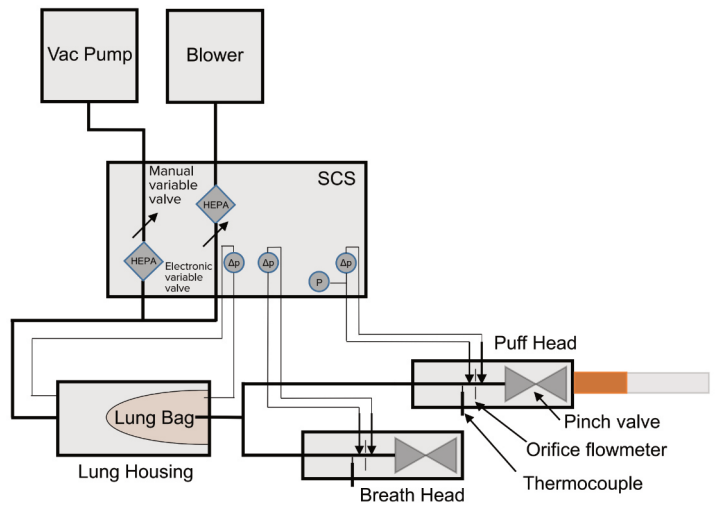

Smoking or vaping aerosol generated in the puff head is sampled into the lung bag. Once in the lung bag, it may be diluted with fresh air inhaled via the breath head. Finally the contents of the lung bag may be exhaled through the breath head. This configuration is relevant if studying evolution of aerosol (the timing of inhalation / exhalation is user programmable). It also affords the user the opportunity to decouple the flow rates through the product under test and downstream collection / analysis instruments.

Gas bag sampling configuration

For collection of aerosol and gas for chemical analysis, including on a puff-by-puff basis, a gas sampling bag is used. Aerosol generated in the puff head is sampled into the Tedlar® gas bag. Once in the gas bag, the sample may be sealed by closing the valve, and a fresh bag fitted for subsequent testing.

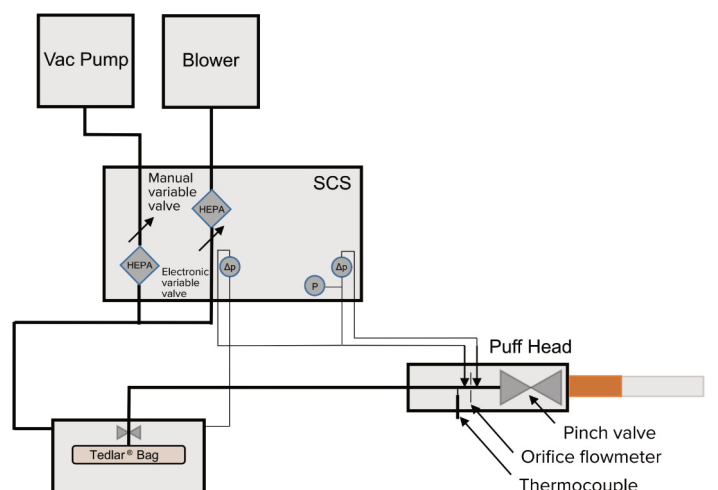

Capabilities

Flexible puff profiles

The SCS offers fully programmable and unlimited puff volume and puff duration, across a wide range of flows.

Standard regimes such as ISO 3308, 5501, 6565, 17957:2024, 20768, 22486 and Health Canada Intense are pre-programmed, while users can also design their own regime.

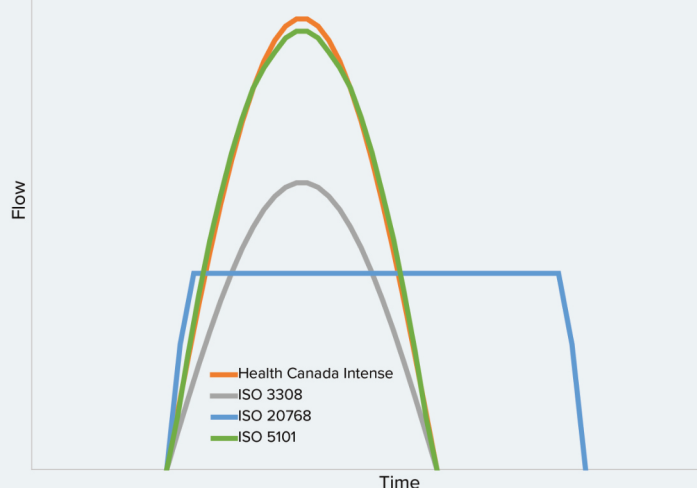

Online analysis

SCS generated aerosol may be sent to a range of online analytical devices, including fast particle sizers such as Cambustion's DMS500.

Gas & aerosol sampling options

Aerosol and gases produced during smoking / vaping may be collected for analysis in a variety of ways.

Gas bag

A unique gas bag housing allows collection of vapour and aerosol in a Tedlar gas bag - ensuring more complete capture compared with techniques such as liquid impingers or filters.

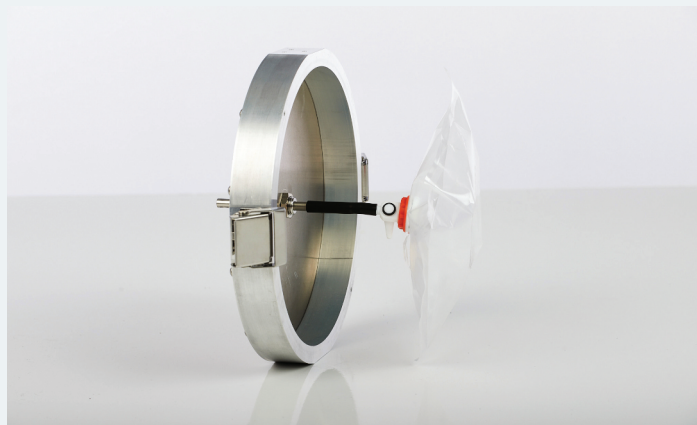

The bag can contain a single puff, or a series of puffs. Once the isolating valve is closed, the bag contents are then available for solvent extraction and analysis by HPLC, GC-MS and other analytical techniques.

Analysis of collected material on a puff-by-puff basis allows the progressive release of species of interest - including THC, CBN, CBD and more. The collected material can also be checked for a range of potential contaminants.

Filter pad collection

An optional stainless steel filter holder allows material to be collected onto a filter pad, for mass or chemical analysis.



Sorbent tubes, cold traps & liquid impingers

The SCS supports collection of both aerosol particles and gases. Collection techniques include sorbent tubes, cold traps & liquid impingers with a variety of solvents, chosen to suit subsequent analysis techniques and species of interest.

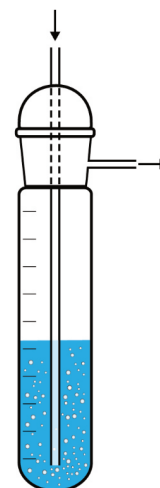

Comprehensive data recording

The SCS records all operating parameters continuously, allowing instant access to information such as flow rate, resistance to draw and actual puff volumes. Every event is recorded in full detail by default, for traceability even months afterwards.

An additional thermocouple option allows recording of a user selected temperature, for example coil/wick, mouthpiece exit or battery temperature.

Flexible automatically generated reports

Users can design their own reports, which are automatically generated as PDFs at the end of a profile. These reports offer an easy way to visualise data, enabling a robust Standard Operating Procedure and maintaining traceability.

E-cigarette Button Pusher

An optional actuator is available for repeatable and programmable activation of manually triggered e-cigarettes.

Pressure drop / resistance to draw

When preparing combustible product, leaf characteristics and packing density affect the resistance to draw of the final product.

The SCS measures the resistance to draw, either of an unlit product, or as a combustible burns, affording insights into product variability and clogging.

Pressure drop measurements for e-cigarettes is also helpful to understand potential clogging and consumer acceptance issues.

A profile for ISO 6565 is provided, and custom test protocols may also be defined.

Low Maintenance

Syringe free design reduces maintenance requirements compared with conventional machines. All parts exposed to aerosol are user cleanable, with long intervals between maintenance.

Software

Intuitive Windows software allows even inexperienced users to create profiles, run smoking/vaping routines and check SCS calibration.

The software is a multi-PC licence, allowing equipment to be shared between labs without needing to move the PC.

API as standard

Easy to use as standalone equipment, the SCS also features an API, allowing advanced users to integrate the SCS with other systems.

Traceable calibration



Every SCS is provided with a traceable calibration certificate, and users can easily connect external reference flow meters for in the field validation and traceability if desired.

Cambustion is an independent, privately owned company with headquarters in Cambridge, UK and customers in more than 30 countries worldwide

Cambustion continue to research & develop novel instrumentation, and now also offer Measurement Consultancy; helping our global clients to solve a wide range of particle and gas measurement issues.



To learn more, visit:

cambustion.com

or contact:

support@cambustion.com

Specifications

Parameter	Specification
Maximum puff flow rate	50 cc/s standard, 250 cc/s option, enquire for custom
Maximum puff duration	Unlimited
Maximum puff volume	Unlimited
Puff repeats	Unlimited
Puff frequency	Infinitely variable
Vaping angle / orientation	Unrestricted
Error in puff volume	<5%
Power supply (market specific)	100, 110 or 220 VAC, 50/60 Hz
Power consumption (including PC)	300 W
System total weight (excluding PC)	Typically 18 kg Heaviest component <7 kg
Smoking /vaping profiles	ISO 3308, 5501, 6565, 17957:2024, 20768, 22486, Health Canada Intense, Custom
Profile following	Maximum 25 Hz
Sampling head temperature	Optionally controllable, maximum 50°C
Data logging	Routine data logging of flow rate, resistance to draw and all operational parameters
Compatible products	Tabacco cigarettes, cigars, pre-rolls, e-cigarettes, vaporisers, heat-not-burn, water pipes
Number of channels	1 (singles cigarette or product)
Product size	Standard holder supports 5-10 mm diameter round. Custom adaptors for other shapes available. Flexible pipe adaptor available for development
Combustible products ignition	Manual, by user with on screen prompt
e-cigarette actuation	Optional button pusher accessory
All specifications subject to change without notice	

Global HQ | UK

J6 The Paddocks
347 Cherry Hinton Road
Cambridge
CB1 8DH
United Kingdom

Tel. +44 1223 210250
USA & Canada: 1-800-416-9304